

TV-AM-FM Digital Antenna Nargentus®

Nargentus is an digital omni-directional, wideband TV-AM-FM receiving antenna (0.1 - 890 MHz) for marine use, especially on crafts equipped with one or two radio and TV sets; e.g. on coasters in limited international trade, fishing-boats, tugs, pilot service and rescue cruisers.

Nargentus is a newly designed low profile antenna, utilizing a low-noise amplifier powered via the coaxial cable.

High efficiency suppression filters prevent interference from VHF telephone and AIS transmitters.

The antenna's exterior is made of composite light-weight material in white finish which requires no maintenance.

All inner parts are embedded in polyurethane foam to protect the antenna from vibrations and water and it is tested by Det Norske Veritas.

Connections, bolts and antenna elements are made of stainless acidproof steel.

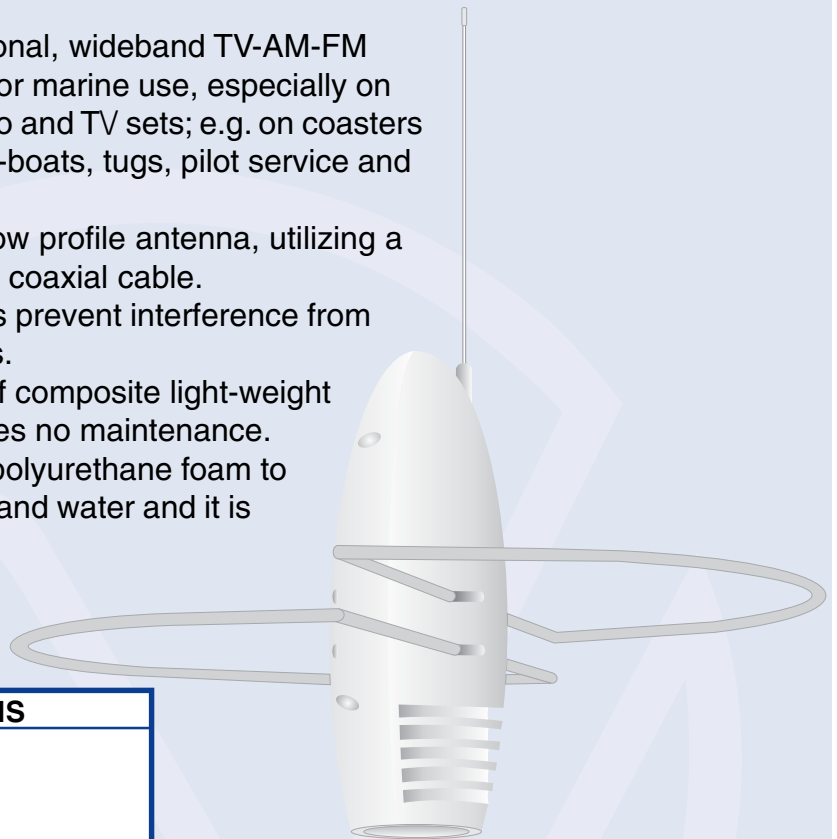

Size: (H) 636 x (W) 400

TECHNICAL SPECIFICATIONS

Frequency range

AM: 0.1 - 30 MHz
TV/FM: 40 - 890 MHz

Average gain: 25 dB
Noise figure: max 4.5 dB
Max. output level: 110 dB μ V
(2 signals-60 dB IMA)

Supply voltage to antenna: 15 V DC \pm 10%
Current consumption: approx 165 mA

Surge

AM: 6 kV
TV/FM: 6 kV
CE-EMC: EN 50083-2, EN 610003-2-2000
EN 61000-3-3:1995+A1:2001

Temperature range: -40° - +60° C
Connectors: 75 ohm BNC female
Weight: 1 kg

Wavetraps

VHF: 156 MHz
AIS: 162 MHz

Certification notes

Det Norske Veritas, DNV
Vibration test: IEC 60068-2-6, April 2005

Material

Housing only: Nylon66+glasfibre IP68
Elements: Stainless acidproof steel (A4/SUS304)



The advantages of Nargentus compared to an ordinary Yagi antenna are

- Rigid, non-corrodible, maintenance-free construction
- Small dimensions, easy to mount
- Omni-receiving, no adjustments

The amplifier increases the sensitivity of the system as well as compensates for cable-losses in the antenna download.

The circuitry is protected against static charge. Nargentus is delivered with 25 metres of 75 ohms low loss double shielded coaxial cable.

0710

Since 1971, the objective of Naval Electronics has been to offer the best possible products for TV and Radio reception at sea. Naval began with omnidirectional antennas and is the world leader in this field of technology today. Now, with an expanded product range, the name Naval means much more than antennas. Naval operates in more than 40 countries and has installations on thousands of vessels all over the world.

All specifications stated are subject to change without notice.



Naval

Marine Broadband Communication

Naval Electronics AB

Höjdrodergatan 18, SE-212 39 Malmö, Sweden

Tel. +46(0)40-29 20 45. Fax +46(0)40-18 74 13

E-mail: sales@naval.se Web:www.naval.se



SS-EN ISO 9001

3036

TV-AM-FM Digital Antenna Nargentus®

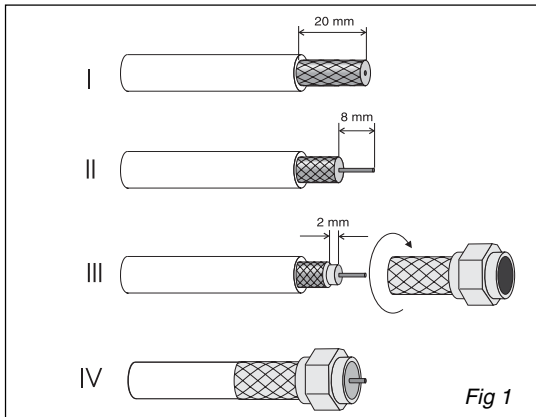

Fig 1

Antenna unit

The antenna should be mounted as high as possible and placed away from masts and funnels and not in same level as radio communication antennas and radars to avoid reflections and interference. The superior location is at the masthead, with free path in all directions. The antenna can be mounted on a 1.5" —2" or 40—50 mm mast tube, deckmounting flange or mounting bracket. The coaxial cable download should be well protected and secured to the mast. Unload the download cable by means of cable clamps and protect it from mechanical damage. Avoid outdoor cable joints, but if necessary, make sure it is waterproof by using self-vulcanizing rubber tape or similar. Avoid excessive bending at the coaxial cable. Factors, such as transmitting power, polarization, radiation angle and antenna height affect the received signal strength and picture quality.

Installation of the PS16 power supply

A. Mount the power supply indoors on the bulkhead by means of two screws. If PS16 is to be mounted on a steel bulkhead, the chassis on the power supply must be galvanic isolated from the bulkhead. Don't forget to use plastic bushing to isolate all the mounting screws.

Note. The PS16 Power supply is not waterproof. Do not connect the supply voltage until the installation is completed.

B. Strip the download coaxial cable and twist on the F-connector, see fig. 1. Make sure that no parts of the braid are short-circuiting the inner conductor. Connect the cord to the terminal marked "antenna". See fig.2.

Strip the TV/Radio coaxial cable and twist on the F-connector. Connect the cord to one of the terminals marked "TV/Radio output" or use the enclosed 1.5 m TV cord with F-IEC TV connectors.

Note. To achieve optimum performance, it is essential that the total cable length (between antenna and TV/Radio-set) is not longer than 25 m (80 ft). The coaxial cable must be a low loss double shielded 75 ohm type. Secure the coaxial cable by means of clamps and avoid excessive bends and sharp edges. Always terminate any unused TV/Radio output with the supplied terminator plug for optimum result.

C. Connect the supply voltage input to the terminals marked GND and +. The terminal accepts 12—30 V DC.

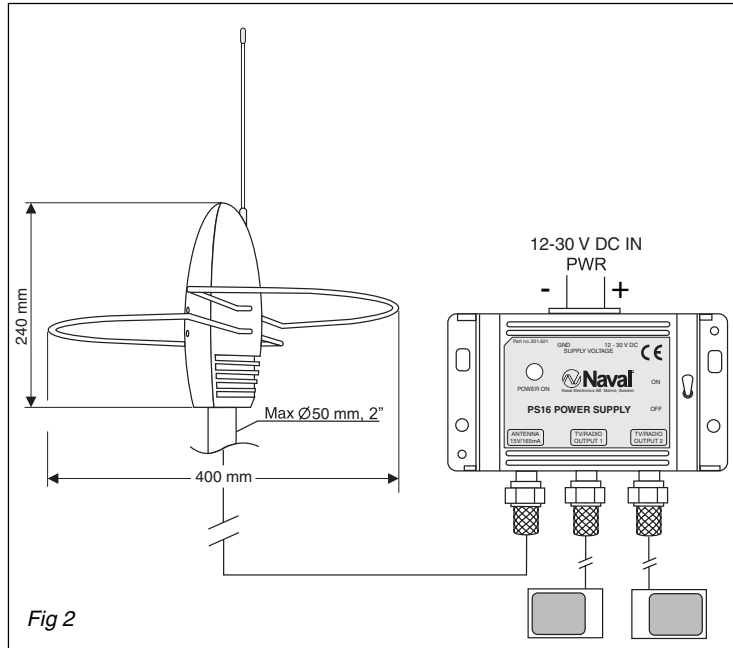

Fig 2

Install the fuseholder with a T400 mA fuse in the positive branch of the power cable. If AC is required please use a local adapter.

Note. Inspect the completed installation. Check supply voltage and polarity before switch on. Turn the switch on the right side of PS16 to activate the built in amplifier of the antenna.

D. Tune your TV/Radio-set and check sound/picture quality.

Note. In some ports severe reflections from buildings, cranes etc. can cause distortion due to the nature of the omni-directional receiving antenna.

In some areas, close to transmitters, overloading of the amplifier and/or TV/Radio-set might occur.

Under these circumstances do not interfere with the installation or the TV/Radio-set.

Accessories

Deckmounting flange in stainless steel: 38mm

Diameter: 105 mm, 4.2"

Height: 60 mm, 2.4"

Mounting bracket in stainless steel 38mm

Length: 395 mm, 16"

Height: 100 mm, 4"

Trouble shooting

If the system is not working properly, please check the following:

1. Proper supply voltage to power supply.
2. Connections.
3. Output voltage from power supply (should be 15 V DC \pm 10%).
4. Antenna current (approx. 165 mA).